

**ROSS CONTROLS®**



---

## **SAFETY EXHAUST (DUMP)**

**CONTROL RELIABLE DOUBLE VALVES FOR CLUTCH/BRAKE CONTROL**  
**SERPAR® 35 SERIES**

---

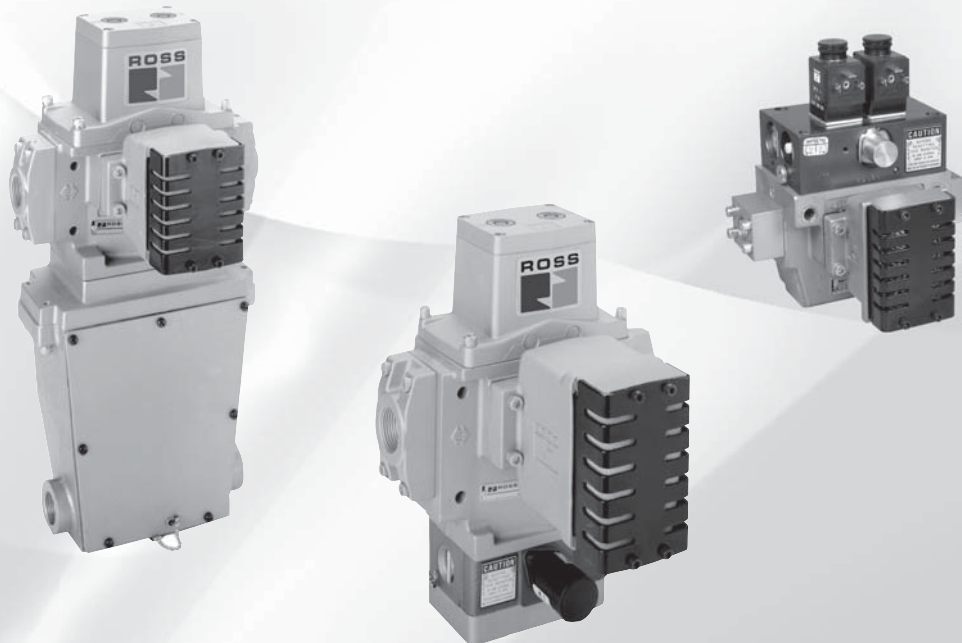





**SERPAR® DOUBLE VALVES 35 SERIES DOUBLE VALVES WITH INTERNAL MONITORING AND RESET – KEY FEATURES**

- Internal monitoring – requires no additional monitoring circuitry
- Automatic lock-out/inhibit upon detection of a malfunction
- Default to de-energized position upon fault detection
- Dedicated reset function
- No undesired automatic reset upon removal of electrical or pneumatic energy sources
- Built-in non-clogging silencers

35 Series SERPAR® valves are internally monitored double valves and are available in Basic Size 4, 8, 12 and 30 ranging from 3/8” – 1½” port sizes. Internally monitored double valves contain a built-in monitoring device that checks for the proper operation of each valve element. If the internal monitor detects a valve fault on a particular cycle, the double valve will fail to a safe condition (all downstream air is exhausted) and the monitor will lock-out to inhibit further operation of the device. Normal operation can only be resumed by a momentary reset signal to the valve, either pneumatic or electric.

The original application for these double valves was in the control of clutch/brake mechanisms on stamping presses, but they have found their way into many other critical applications such as alternative lockout systems for energy isolation, air cylinder press load-holding systems, as well as other Category -3 and -4 safety circuits. ROSS double valves are a vital part of any control-reliable fluid power control system.

DESCRIPTION		Page
SERPAR® Double Valves with Internal Monitoring and Pneumatic Reset L-G Monitor Size 4		G2.3 - G2.4
SERPAR® Double Valves with Internal Monitoring and Pneumatic Reset L-G Monitor Size 8, 12, 30		G2.5 - G2.6
SERPAR® Double Valves with Internal Monitoring and Pneumatic Reset E-P Monitor Size 8, 12, 30		G2.7 - G2.8
SERPAR® Double Valves with Internal Monitoring and Dry Contact Reset D-S Monitor Size 8, 12, 30		G2.9 - G2.10

# SERPAR® Double Valves with Internal Monitoring and Pneumatic Reset – L-G Monitor

## Safety Exhaust (Dump) 35 Series

### Basic Size 4

Port Size	Basic Size	Monitor Reset	Model Number*		C <sub>v</sub>		Avg. Response Constants			Weight lb (kg)
			Right Inlet	Left Inlet	1-2	2-3	M	F		
								1-2	2-3	
3/8	4	Manual	3573D3191**	3573D3195**	3	6	15	0.70	0.40	8.3 (3.7)
		Remote	3573D3192**	3573D3196**	3	6	15	0.70	0.40	8.3 (3.7)
1/2	4	Manual	3573D4211**	3573D4215**	3	8	15	0.65	0.35	8.3 (3.7)
		Remote	3573D4212**	3573D4216**	3	8	15	0.65	0.35	8.3 (3.7)
3/4	4	Manual	3573D5211**	3573D5215**	3	9	15	0.65	0.35	8.3 (3.7)
		Remote	3573D5212**	3573D5216**	3	9	15	0.65	0.35	8.3 (3.7)

\* NPT port threads. For BSPP threads, add a "D" prefix to the model number, e.g., D3573D3191W.  
 \*\* Insert voltage code: "W" = 24 volts DC; "Z" = 110-120 volts AC, 50/60 Hz; e.g., 3573D3191W.  
 For other voltages consult ROSS.

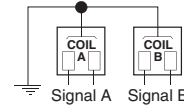

### Valve Response Time

The constants above, designated M and F, can be used to determine the amount of time required to fill or exhaust a volume of any size using the formula on the right:

**Vlv. Resp. Time (msec) = M + F \* V**  
**M** = avg. time for parts movement  
**F** = msec. per cubic inch of volume  
**V** = volume in cubic inches

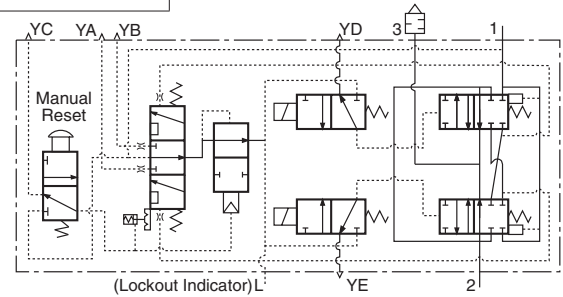

G2

### ACCESSORIES & OPTIONS

#### Pressure Switches

(Electrical Lockout Indicator)

Connection Type	Model Number*	Port Threads
EN 175301-803 Form A	586A86	1/8 NPT
M12	1153A30	1/8 NPT

\* Pressure switch closes on falling pressure of 5 psig (0.34 bar).

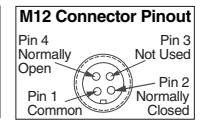
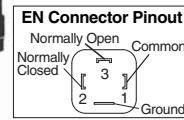
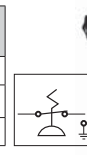

#### Piping Flange Kits

Each kit includes two threaded (NPT) flanges and the required seals and mounting bolts.

Port Size	Basic Size	Kit Number
3/8	4	658K77
1/2	4	659K77
3/4	4	660K77

#### Valve Without Piping Flanges

Port Size	Basic Size	Monitor Reset	Model Number*	
			Right Inlet	Left Inlet
3/8, 1/2, 3/4	4	Manual	3573D4241**	3573D4245**
		Remote	3573D4242**	3573D4246**

### RESET VALVES for L-G MONITOR

On valve models with manual reset a button on the side of the monitor is pushed to perform the reset function. Models for remote reset, however, require a small reset valve and the installation of a 1/8 line from the reset valve to the reset port on the monitor. ROSS offers 3/2 normally closed valves with either manual or electric control that are suitable for this purpose, valves size 8, 12, 30 with L-G monitor are suggested.

#### Reset Valves

Description	Model Numbers
Flush Pushbutton: Green	1223B1FPG
Mushroom Button: Green	1223B1MBG
Direct Solenoid Control for Line Mounting	1613B1020**
Direct Solenoid Control for Base Mounting	W1413A1409** (Base: 516B91)

\* NPT port threads. For BSPP threads, add a "D" prefix to the model number, e.g., D3573D4241W.

\*\* Insert voltage code: "W" = 24 volts DC; "Z" = 110-120 volts AC, 50/60 Hz; e.g., 3573D4241W. For other voltages consult ROSS.

**Valve Without Silencer** Exhaust port has threaded flange only, consult ROSS.

### STANDARD SPECIFICATIONS (for valves on this page):

**Construction:** Dual poppet.

**Mounting Type:** Inline.

**Pilot Solenoids:** Two, rated for continuous duty.

**Standard Voltages:** 24 volts DC; 110-120 volts AC, 50/60 Hz.

**Power Consumption** (each solenoid): 30 VA inrush, 16 VA holding on 50 or 60 Hz; 11 watts on DC.

**Enclosure Rating:** IP65, IEC 60529.

**Electrical Connections:** EN 175301-803 Form A, uses two cord-grip connectors at solenoids.

**Ambient Temperature:** 40° to 120°F (4° to 50°C).

**Media Temperature:** 40° to 175°F (4° to 80°C).

**Flow Media:** Filtered air.

**Inlet Pressure:** 30 to 100 psig (2 to 7 bar).

**L-G Reset Pressure:** Remote pneumatic reset models require a pressure of at least 30 psig (2 bar). Manual reset models use internal valve pressure.

**Inlet Port:** Models are available with the inlet port on either the right or the left side of the valve body.

**IMPORTANT NOTE:** Please read carefully and thoroughly all of the **CAUTIONS, WARNINGS** on the inside back cover.



Online Version  
Rev. 10/02/17

www.rosscontrols.com

G2.3

G

### Basic Size 4

#### Valve Dimensions – inches (mm)

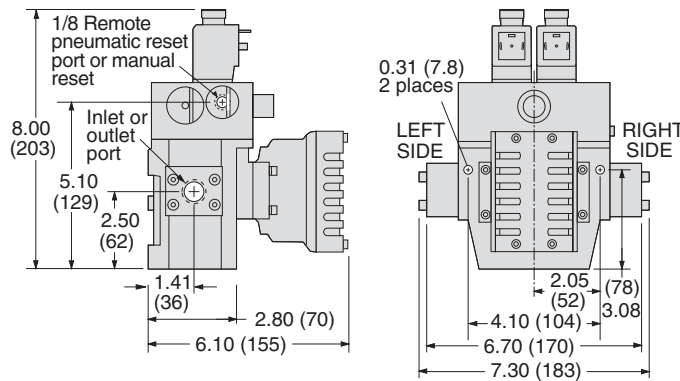

### OPTIONS

Electrical Connectors	Electrical Connector Form	Electrical Connector Type	Cord Length meters (feet)	Cord Diameter	Electrical Connector Model Number		
					Without Light	Lighted Connector	
						24 Volts DC	120 Volts AC
	EN 175301-803 Form A	Prewired Connector (18 gauge)	2 (6½)	6-mm	721K77	720K77-W	720K77-Z
		Prewired Connector (18 gauge)	2 (6½)	10-mm	371K77	383K77-W	383K77-Z
		Connector for threaded conduit (1/2 inch electrical conduit fittings)	–	–	723K77	724K77-W	724K77-Z
		Connector Only	–	–	937K87	936K87-W	936K87-Z

**CAUTIONS:** Do not use electrical connectors with surge suppressors, as this may increase valve response time when de-actuating the solenoids.

## VALVE OPERATION

#### Conditions at Start:

Inlet 1 is closed to outlet 2 by both valve elements A and B. Outlet 2 is open to exhaust 3. Pilot air is ported from inlet 1 and through the center section of spool S to the normally closed pilots Pa and Pb. Monitoring pressure signals at both ends of spool S are exhausted.

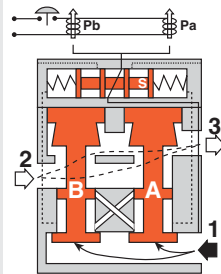

#### Detecting a Malfunction:

A malfunction in the system or the valve itself could cause one valve element to be open and the other closed. Air then flows past the inlet poppet on valve element A, into crossflow passage D, but is substantially blocked by the spool portion of element B. The large size of the open exhaust passage past element B keeps the pressure at the outlet port below two percent of inlet pressure. Full monitoring air pressure from side A goes to the right end of spool S, and a reduced pressure goes to the left end. This pressure imbalance causes the spool to shift to the left. This shuts off and exhausts pilot air to both solenoid pilots, and allows valve element A to return to the closed position.

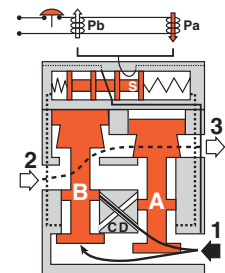

#### Normal Operation:

Simultaneously energizing both solenoids actuates both pilots and causes valve elements A and B to shift. Inlet 1 is then connected to outlet 2 via crossflow passages C and D. Exhaust 3 is closed. Monitoring pressure signals go to each end of spool S and become equal to inlet pressure.

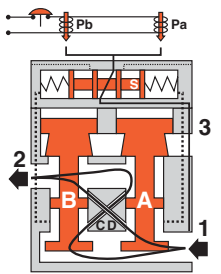

#### L-G Monitor Locked-out:

When the L-G spool shifts it is held by a lockout pin (not shown). Pilot air is then exhausted to atmosphere via port YB, and pilot supply air is diverted to atmosphere via port YA. The lockout mechanism must be reset before the valve can return to normal operation. *During and following reset, the pilot solenoids must be kept de-energized to prevent inadvertent and possibly dangerous cycling of the press.* The reset function is either manual or remote-pneumatic depending on valve model.

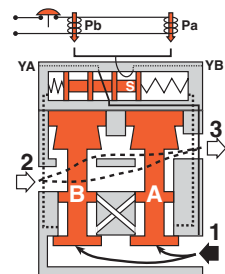

Both solenoids must be energized simultaneously to shift the valve; maintained signal required to keep valve shifted.

**WARNING:** If monitor must be reset, electrical signals to both solenoids must be removed to prevent the machine controlled by the valve from immediately recycling and producing a potentially hazardous condition.

# SERPAR® Double Valves with Internal Monitoring and Pneumatic Reset – L-G Monitor

## Safety Exhaust (Dump) 35 Series

### Basic Size 8, 12, 30

Port Size	Basic Size	Model Number*		C <sub>v</sub>		Avg. Response Constants			Weight lb (kg)
		With Overrides	Without Overrides	1-2	2-3	M	F		
							1-2	2-3	
1/2	8	3573A4142**	3573A4162**	3.5	8.5	15	0.70	0.30	15.3 (6.9)
	8	3573A5142**	3573A5162**	4.0	12	15	0.65	0.23	
3/4	12	3573A5152**	3573A5172**	8.0	15	15	0.65	0.23	19.0 (8.6)
	8	3573A6152**	3573A6172**	4.0	12	20	0.33	0.21	
1	12	3573A6162**	3573A6182**	8.5	19	20	0.28	0.21	19.0 (8.6)
	12	3573A7162**	3573A7182**	9.0	21	20	0.28	0.21	
1 1/4	30	3573A7152**	3573A7172**	20	42	25	0.19	0.07	37.5 (16.9)
	30	3573A8162**	3573A8182**	21	43	25	0.18	0.07	
2	30	2 inch port size available on size 30 valves. Order model number 1999H77 flange kit separately.							

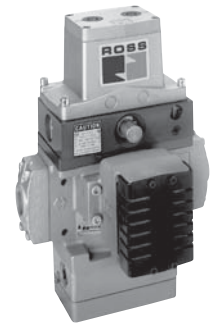

G2

\* NPT port threads. For BSPP threads, add a "D" prefix to the model number, e.g., D3573A4142W.  
 \*\* Insert voltage code: "W" = 24 volts DC; "Z" = 110-120 volts AC, 50/60 Hz; e.g., 3573A4142W.  
 For other voltages consult ROSS.

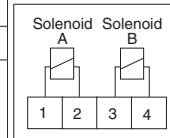

**Valve Response Time** The constants above, designated M and F, can be used to determine the amount of time required to fill or exhaust a volume of any size using the formula on the right:

**Vlv. Resp. Time (msec) = M + F \* V**  
**M** = avg. time for parts movement  
**F** = msec. per cubic inch of volume  
**V** = volume in cubic inches

### ACCESSORIES & OPTIONS

#### Pressure Switches

(Electrical Lockout Indicator)

Connection Type	Model Number*	Port Threads
EN 175301-803 Form A	586A86	1/8 NPT
M12	1153A30	1/8 NPT

\*Pressure switch closes on falling pressure of 5 psig (0.34 bar).

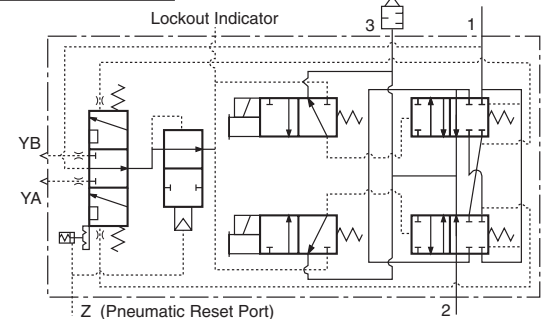
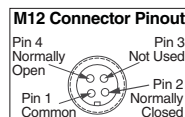
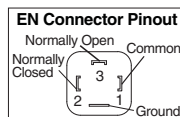

#### Valve Without Piping Flanges

Port Size	Basic Size	Model Number*	
		With Overrides	Without Overrides
1/2, 3/4, 1	8	3573A4202**	3573A4222**
3/4, 1, 1 1/4	12	3573A5202**	3573A5222**
1 1/4, 1 1/2	30	3573A7202**	3573A7222**

#### Piping Flange Kits

Each kit includes two threaded (NPT) flanges and the required seals and mounting bolts.

Port Size	Basic Size	Pipe Flange Kit Model Number
1/2	8	661K77
	8	662K77
3/4	12	664K77
	8	663K77
1	12	665K77
	12	666K77
1 1/4	30	667K77
	30	668K77

### RESET VALVES for L-G MONITOR

Models for remote reset, however, require a small reset valve and the installation of a 1/8 line from the reset valve to the reset port on the monitor.

Reset Valves	
Description	Model Number*
Flush Pushbutton: Green	1223B1FFG
Mushroom Button: Green	1223B1MBG
Direct Solenoid Control for Line Mounting	1613B1020**
Direct Solenoid Control for Base Mounting	W1413A1409** (Base: 516B91)

G

\* NPT port threads. For BSPP threads, add a "D" prefix to the model number, e.g., D3573A4202W.

\*\* Insert voltage code: "W" = 24 volts DC; "Z" = 110-120 volts AC, 50/60 Hz; e.g., 3573A4202W. For other voltages consult ROSS.

**Valve Without Silencer** Exhaust port has threaded flange only, consult ROSS.

### STANDARD SPECIFICATIONS (for valves on this page):

**Construction:** Dual poppet.

**Mounting Type:** Inline.

**Pilot Solenoids:** Two, rated for continuous duty.

**Standard Voltages:** 24 volts DC; 110-120 volts AC, 50/60 Hz.

**Power Consumption** (each solenoid): 87 VA inrush, 30 VA holding on 50 or 60 Hz; 14 watts on DC.

**Electrical Connections:** Uses terminal strip connectors.

**Ambient Temperature:** 40° to 120°F (4° to 50°C).

**Media Temperature:** 40° to 175°F (4° to 80°C).

**Flow Media:** Filtered air.

**Inlet Pressure:** 30 to 125 psig (2 to 8.5 bar).

**L-G Reset Pressure:** 60 psig (4 bar) minimum.

**IMPORTANT NOTE:** Please read carefully and thoroughly all of the **CAUTIONS, WARNINGS** on the inside back cover.



Online Version  
Rev. 10/02/17

www.rosscontrols.com

G2.5

**Basic Size 8, 12, 30**

**Valve Dimensions – inches (mm)**

**Basic Size 8**

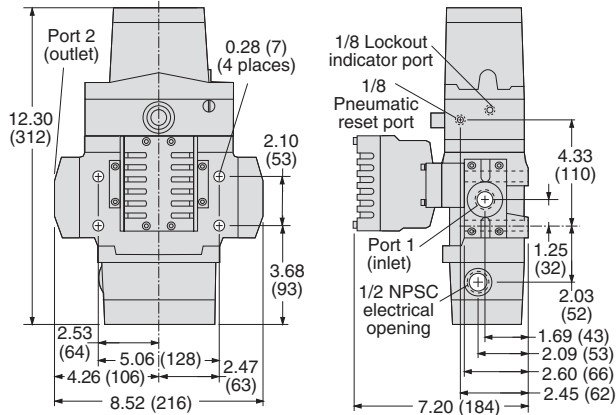

**Basic Size 12**

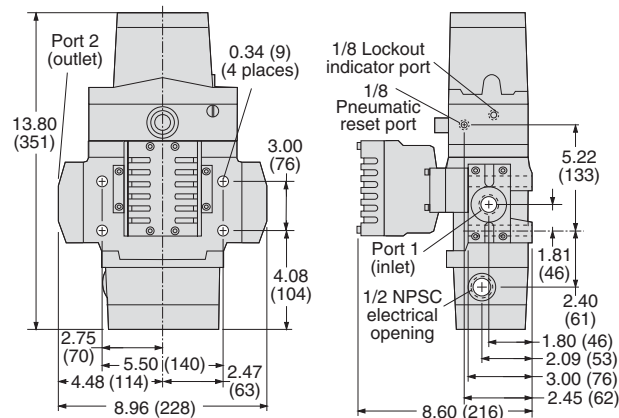

**Basic Size 30**

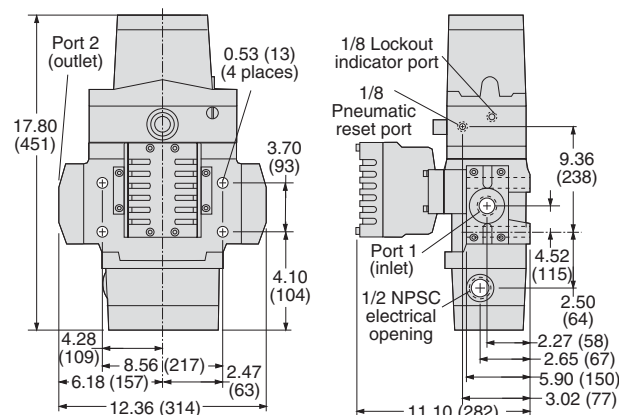

**VALVE OPERATION**

**Conditions at Start:**

Inlet 1 is closed to outlet 2 by both valve elements A and B. Outlet 2 is open to exhaust 3. Pilot air is ported from inlet 1 and through the center section of spool S to the normally closed pilots Pa and Pb. Monitoring pressure signals at both ends of spool S are exhausted.

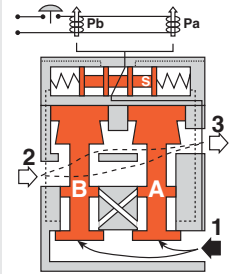

**Normal Operation:**

Simultaneously energizing both solenoids actuates both pilots and causes valve elements A and B to shift. Inlet 1 is then connected to outlet 2 via crossflow passages C and D. Exhaust 3 is closed. Monitoring pressure signals go to each end of spool S and become equal to inlet pressure.

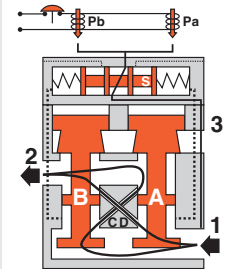

**Detecting a Malfunction:**

A malfunction in the system or the valve itself could cause one valve element to be open and the other closed. Air then flows past the inlet poppet on valve element A, into crossflow passage D, but is substantially blocked by the spool portion of element B. The large size of the open exhaust passage past element B keeps the pressure at the outlet port below two percent of inlet pressure. Full monitoring air pressure from side A goes to the right end of spool S, and a reduced pressure goes to the left end. This pressure imbalance causes the spool to shift to the left. This shuts off and exhausts pilot air to both solenoid pilots, and allows valve element A to return to the closed position.

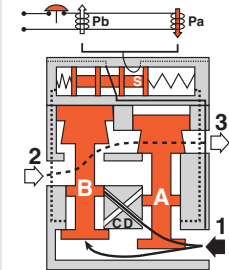

**L-G Monitor Locked-out:**

When the L-G spool shifts it is held by a lockout pin (not shown). Pilot air is then exhausted to atmosphere via port YB, and pilot supply air is diverted to atmosphere via port YA. The lockout mechanism must be reset before the valve can return to normal operation. *During and following reset, the pilot solenoids must be kept de-energized to prevent inadvertent and possibly dangerous cycling of the press.* The reset function is either manual or remote-pneumatic depending on valve model.

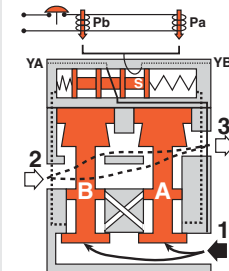

Both solenoids must be energized simultaneously to shift the valve; maintained signal required to keep valve shifted.

**WARNING:** If monitor must be reset, electrical signals to both solenoids must be removed to prevent the machine controlled by the valve from immediately recycling and producing a potentially hazardous condition.

# SERPAR® Double Valves with Internal Monitoring and Solenoid Reset – E-P Monitor

# Safety Exhaust (Dump) 35 Series

Port Size	Basic Size	Model Number*				C <sub>v</sub>		Avg. Response Constants		Weight lb (kg)	
		Single Signal Input		Dual Signal Input							
		With Overrides	Without Overrides	With Overrides	Without Overrides	1-2	2-3	M	F		
1/2	8	3573A4141**	3573A4161**	3573A4341**	3753A4361**	3.5	8.5	15	0.70	0.30	11.8 (5.3)
3/4	8	3573A5141**	3573A5161**	3573A5341**	3573A5361**	4	12	15	0.65	0.23	11.8 (5.3)
	12	3573A5151**	3573A5171**	3573A5351**	3573A5371**	8	15	15	0.65	0.23	15.5 (7.0)
1	8	3573A6151**	3573A6171**	3573A6351**	3573A6371**	4	12	20	0.33	0.21	11.8 (5.3)
	12	3573A6161**	3573A6181**	3573A6361**	3573A6381**	8.5	19	20	0.28	0.21	15.5 (7.0)
1¼	12	3573A7161**	3573A7181**	3573A7361**	3573A7381**	9	21	20	0.28	0.21	15.5 (7.0)
	30	3573A7151**	3573A7171**	3573A7351**	3573A7371**	20	42	25	0.19	0.07	35.0 (15.8)
1½	30	3573A8161**	3573A8181**	3573A8361**	3573A8381**	21	43	25	0.18	0.07	35.0 (15.8)
2	30	2 inch port size available on size 30 valves. Order model number 1999H77 flange kit separately.									



G2

\* NPT port threads. For BSPP threads, add a "D" prefix to the model number, e.g., D3573A4141W.  
 \*\* Insert voltage code: "W" = 24 volts DC; "Z" = 110-120 volts AC, 50/60 Hz; e.g., 3573A4141W.  
 For other voltages consult ROSS.

### Valve Response Time

The constants above, designated M and F, can be used to determine the amount of time required to fill or exhaust a volume of any size using the formula below:

**Vlv. Resp. Time (msec) = M + F \* V**  
**M** = avg. time for parts movement  
**F** = msec. per cubic inch of volume  
**V** = volume in cubic inches

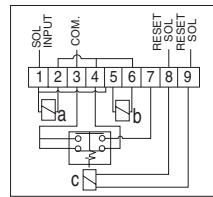

Single Input Wiring Diagram

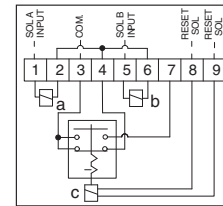

Dual Input Wiring Diagram

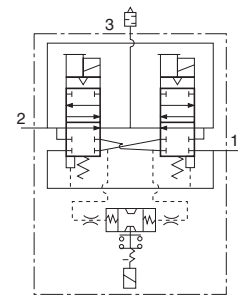

**During lock-out:** Terminals 3 and 7 are connected which allows a panel light, bell, or other electrical device to be wired through terminals 7 and 3 to serve as a lockout indicator.

### OPTIONS

#### Valve Without Piping Flanges

Port Size	Basic Size	Model Number*			
		Single Signal Input		Dual Signal Input	
		With Overrides	Without Overrides	With Overrides	Without Overrides
1/2, 3/4, 1	8	3573A4201**	3573A4221**	3573A4301**	3573A4321**
3/4, 1, 1¼	12	3573A5201**	3573A5221**	3573A5301**	3573A5321**
1¼, 1½	30	3573A7201**	3573A7221**	3573A7301**	3573A7321**

\* NPT port threads. For BSPP threads, add a "D" prefix to the model number, e.g., D3573A4201W.  
 \*\* Insert voltage code: "W" = 24 volts DC; "Z" = 110-120 volts AC, 50/60 Hz; e.g., 3573A4201W. For other voltages consult ROSS.

#### Piping Flange Kits

Each kit includes two threaded (NPT) flanges and the required seals and mounting bolts.

Port Size	Basic Size	Kit Number
1/2	8	661K77
3/4	8	662K77
	12	664K77
1	8	663K77
	12	665K77
1¼	12	666K77
	30	667K77
1½	30	668K77

G

#### Valve Without Silencer

Exhaust port has threaded flange only, consult ROSS.

### STANDARD SPECIFICATIONS (for valves on this page):

**Construction:** Dual poppet.  
**Mounting Type:** Inline.  
**Pilot Solenoids:** Two, rated for continuous duty.  
**Standard Voltages:** 24 volts DC; 110-120 volts AC, 50/60 Hz.  
**Power Consumption** (each solenoid): 87 VA inrush, 30 VA holding on 50 or 60 Hz; 14 watts on DC.

**E-P Reset Solenoid:** Rated for *intermittent* duty. Voltages: 24-48 or 100-120 volts AC or DC.  
**Ambient Temperature:** 40° to 120°F (4° to 50°C).  
**Media Temperature:** 40° to 175°F (4° to 80°C).  
**Flow Media:** Filtered air.  
**Pressure Range:** 30 to 125 psig (2 to 8.5 bar).

**IMPORTANT NOTE:** Please read carefully and thoroughly all of the **CAUTIONS, WARNINGS** on the inside back cover.



Online Version  
Rev. 10/02/17

www.rosscontrols.com

G2.7

### Valve Dimensions – inches (mm)

#### Basic Size 8

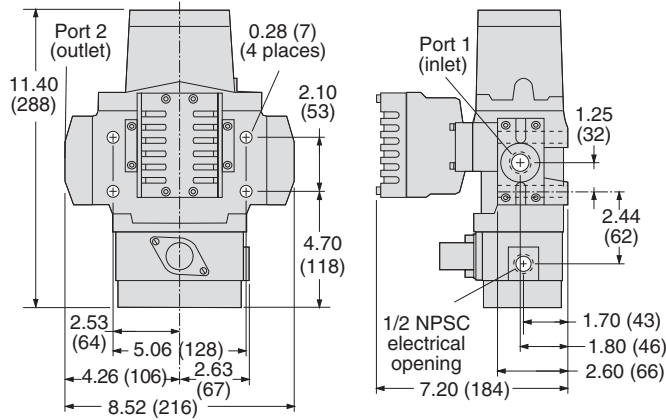

#### Basic Size 12

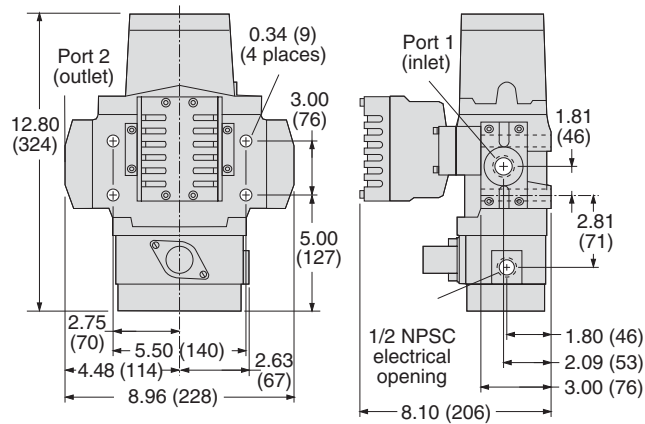

#### Basic Size 30

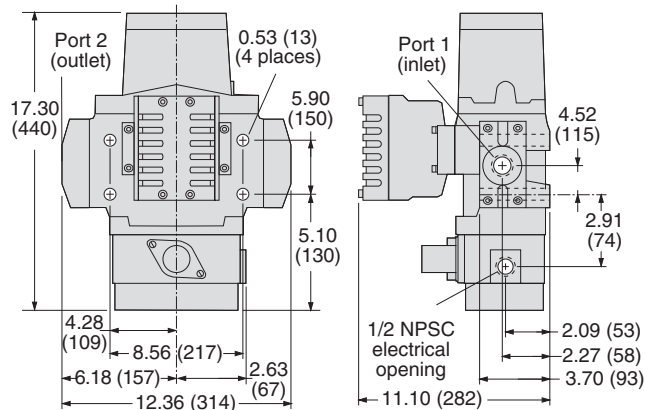

## VALVE OPERATION

### Conditions at Start:

Inlet 1 is closed to outlet 2 by both valve elements A and B. Outlet 2 is open to exhaust 3. Contacts of switch SW are closed. Monitoring pressure signals at both ends of spool S are exhausted.

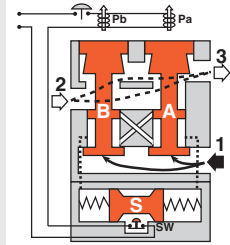

### Normal Operation:

Simultaneously energizing both solenoids actuates both pilots and causes valve elements A and B to shift. Inlet 1 is then connected to outlet 2 via crossflow passages C and D. Exhaust 3 is closed. Monitoring pressure signals go to each end of spool S and become equal to inlet pressure.

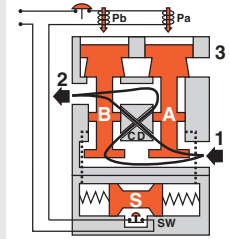

### Completion of Normal Cycle:

Simultaneously de-energizing both solenoids returns the valve to the "Conditions at Start" described above.

### Detecting a Malfunction:

A malfunction in the system or the valve itself could cause one valve element to be open and the other closed. Air then flows past the inlet poppet on valve element A, into crossflow passage D, but is substantially blocked by the spool portion of element B. The large size of the open exhaust passage past element B keeps the pressure at the outlet port below two percent of inlet pressure. Full monitoring air pressure from side A goes to the right end of spool S, and a reduced pressure goes to the left end. This pressure imbalance causes the spool to shift to the left. This trips switch SW, breaks the electrical circuit to the pilot solenoids, and allows valve element A to return to the closed position.

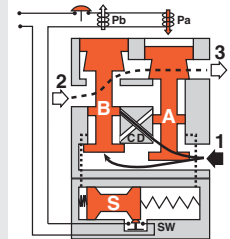

### E-P Monitor Locked-out:

With both valve elements closed, monitoring air pressure is exhausted from both ends of spool S so that it returns to its normal position. The electrical circuit to the pilot solenoids remains broken by switch SW. To restore the electrical circuit and return the valve to normal operation, the reset solenoid (not shown) must be briefly energized to reset switch SW. *During and following reset, the pilot solenoids must be kept de-energized to prevent inadvertent and possibly dangerous cycling of the press.* Prolonged energizing of the reset solenoid can cause burnout and nullify the reset function.

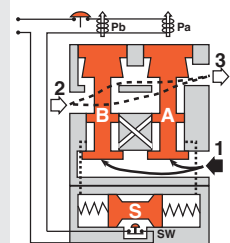

# SERPAR® Double Valves with Internal Monitoring and Dry Contact Reset – D-S Monitor

## Safety Exhaust (Dump) 35 Series

Port Size	Basic Size	Model Number*		C <sub>v</sub>		Avg. Response Constants			Weight lb (kg)
		With Overrides	Without Overrides			M	F		
				1-2	2-3		1-2	2-3	
1/2	8	3573B4143**	3573B4163**	3.5	8.5	15	0.70	0.30	16.8 (7.6)
3/4	8	3573B5143**	3573B5163**	4	12	15	0.65	0.23	16.8 (7.6)
	12	3573B5153**	3573B5173**	8	15	15	0.65	0.23	20.5 (9.2)
1	8	3573B6153**	3573B6173**	4	12	20	0.33	0.21	16.8 (7.6)
	12	3573B6163**	3573B6183**	8.5	19	20	0.28	0.21	20.5 (9.2)
1¼	12	3573B7163**	3573B7183**	9	21	20	0.28	0.21	20.5 (9.2)
	30	3573B7153**	3573B7173**	20	42	25	0.19	0.07	39.3 (17.7)
1½	30	3573B8163**	3573B8183**	21	43	25	0.18	0.07	39.3 (17.7)
2	30	2 inch port size available on size 30 valves. Order model number 1999H77 flange kit separately.							

\* NPT port threads. For BSPP threads, add a "D" prefix to the model number, e.g., D3573B4143W.

\*\* Insert voltage code: "W" = 24 volts DC; "Z" = 110-120 volts AC, 50/60 Hz; e.g., 3573B4143W.

For other voltages consult ROSS.



G2

### Valve Response Time

The constants above, designated M and F, can be used to determine the amount of time required to fill or exhaust a volume of any size using the formula below:

$$Vlv. \text{ Resp. Time (msec)} = M + F * V$$

M = avg. time for parts movement

F = msec. per cubic inch of volume

V = volume in cubic inches

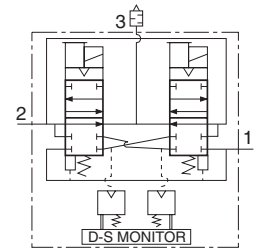
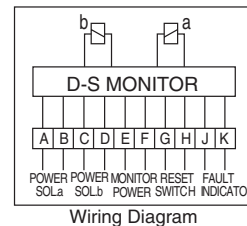

### OPTIONS

Valve Without Piping Flanges	Port Size	Basic Size	Model Number*	
			With Overrides	Without Overrides
	1/2, 3/4, 1	8	3573A4203**	3573A4223**
3/4, 1, 1¼	12	3573A5203**	3573A5223**	
1¼, 1½	30	3573A7203**	3573A7223**	

\* NPT port threads. For BSPP threads, add a "D" prefix to the model number, e.g., D3573A4203W.

\*\* Insert voltage code: "W" = 24 volts DC; "Z" = 110-120 volts AC, 50/60 Hz; e.g., 3573A4203W. For other voltages consult ROSS.

### Piping Flange Kits

Each kit includes two threaded (NPT) flanges and the required seals and mounting bolts.

Port Size	Basic Size	Kit Number
1/2	8	661K77
3/4	8	662K77
	12	664K77
1	8	663K77
	12	665K77
1¼	12	666K77
	30	667K77
1½	30	668K77

G

**Valve Without Silencer** Exhaust port has threaded flange only, consult ROSS.

### STANDARD SPECIFICATIONS (for valves on this page):

**Construction:** Dual poppet.

**Mounting Type:** Inline.

**Pilot Solenoids:** Two, rated for continuous duty.

**Standard Voltages:** 24 volts DC; 110-120 volts AC, 50/60 Hz.

**Power Consumption** (each solenoid): 87 VA inrush, 30 VA holding on 50 or 60 Hz; 14 watts on DC.

**D-S Monitor:** Rated for same voltage as pilot solenoids. Power supply to monitor must be independent and continuous.

**Ambient Temperature:** 40° to 120°F (4° to 50°C).

**Media Temperature:** 40° to 175°F (4° to 80°C).

**Flow Media:** Filtered air.

**Pressure Range:** 30 to 125 psig (2 to 8.5 bar).

**IMPORTANT NOTE:** Please read carefully and thoroughly all of the **CAUTIONS, WARNINGS** on the inside back cover.



Online Version  
Rev. 10/02/17

www.rosscontrols.com

G2.9

### Valve Dimensions – inches (mm)

#### Basic Size 8

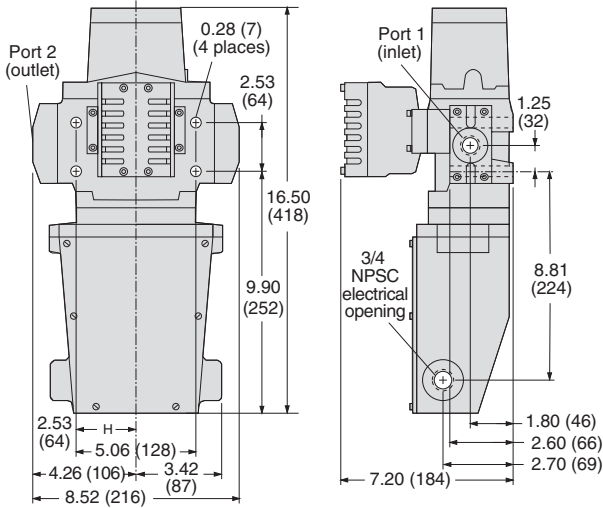

#### Basic Size 12

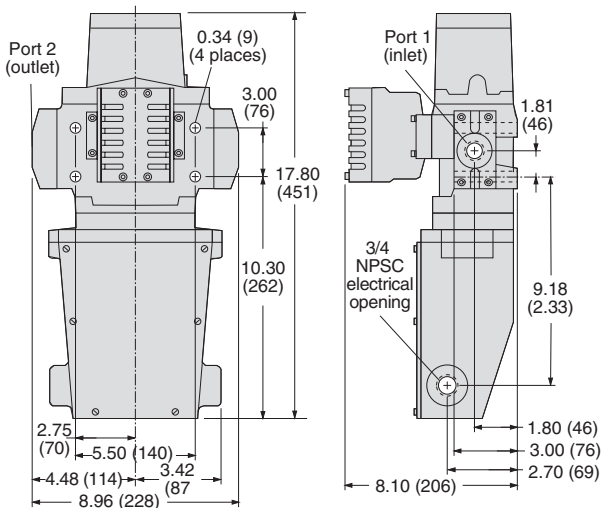

#### Basic Size 30

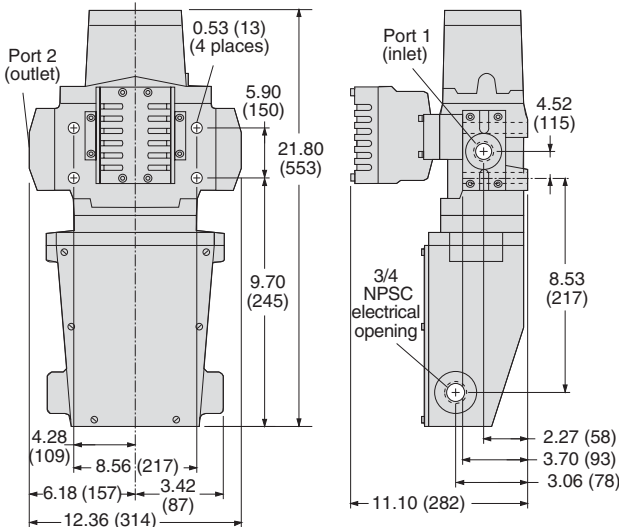

## VALVE OPERATION

### Conditions at Start:

Inlet 1 is closed to outlet 2 by both valve elements A and B. Outlet 2 is open to exhaust 3. Contacts of switch SW are closed. Monitoring pressure signals at both ends of spool S are exhausted.

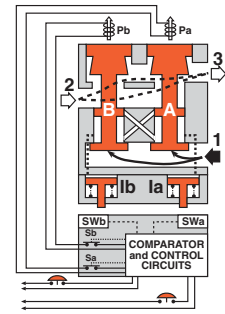

### Normal Operation:

Simultaneously energizing both solenoids actuates both pilots and causes valve elements A and B to shift. Inlet 1 is then connected to outlet 2 via crossflow passages C and D. Exhaust 3 is closed. Monitoring pressure signals go to pressure indicators Ia and Ib, causing the indicator pins to be extended and to actuate proximity switches SWa and SWb. In normal operation, each pair - solenoids, valve elements, indicators, and proximity switches - responds in unison so that the comparator circuits "read" the operation as normal.

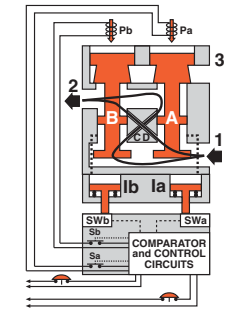

### Completion of Normal Cycle:

Simultaneously de-energizing both solenoids returns the valve to the "Conditions at Start" described above.

### Detecting a Malfunction:

A malfunction in the system or the valve itself could cause one valve element to be open and the other closed. Air then flows past the inlet poppet on valve element A, into crossflow passage D, but is substantially blocked by the spool portion of element B. The large size of the open exhaust passage past element B keeps the pressure at the outlet port below two percent of inlet pressure. Full monitoring air pressure from side A goes to pressure indicator Ia so that its pin is extended and actuates proximity switch SWa. When the time interval between the signal to a solenoid and the signal from its corresponding proximity switch exceeds approximately 175 milliseconds, the D-S monitor breaks contacts Sa and Sb as soon as solenoid power is removed. This allows valve element A to return to the closed position.

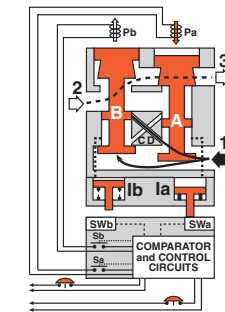

### D-S Monitor Locked-out:

With the valve locked out by contacts Sa and Sb, solenoids Pa and Pb cannot be energized. The monitor must be reset before another valve cycle can begin. Reset can be achieved by a separately connected ancillary switch, but not if the pilot solenoids are energized. The monitor can be reset by removing and reapplying power to the monitor even when the pilot solenoids are energized. For this reason it is necessary to have the pilot solenoids de-energized during and following reset to prevent inadvertent and possibly dangerous cycling of the press.

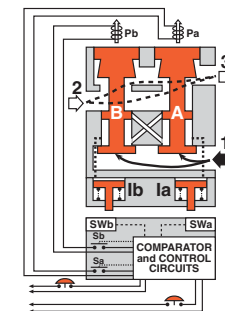

G2

G

G2

G



G





# General Information

## Standard Specifications

The standard specifications for the products on each page of this catalog are given on the same page or referenced. For solenoid pilot valves, models with internal pilot supply are listed. Most models are also available for use with external pilot supply or have a built-in pilot supply selector valve.

The products in this catalog are intended for use in industrial pneumatic systems. Most products are adaptable to other uses and conditions not covered by the standard specifications given in this catalog. Weights shown are approximate and are subject to change. Dimensions given, unless otherwise noted, are envelope dimensions (not for mounting). Consult ROSS for further information.

## Port Threads

Ports of valves and bases described in this catalog have NPT (ANSI B2.1) threads. Other thread types can be specified by putting an appropriate prefix letter on the model or part number when ordering.

Thread Types by Model Prefix Letter

Pneumatic Port Threads	Prefix Letter	Threaded Electrical Opening
NPT (ANSI B2.1)	None	NPT
ISO 228 - DIN 259 Parallel, BSPP#	C*	—
ISO 228 - DIN 259 Parallel, BSPP#	D	G
ISO 228 - JIS B0203 Tapered#	J	ISO
SAE 1926- ISO 11926	S	NPT

\* Used only for filters, regulators, lubricators.

# ISO 228 threads supersedes BSPP, G and JIS thread types.

## Flow Ratings

Flow ratings are expressed as  $C_v$  where  $C_v = 1$  corresponds to a steady state air flow of approximately 32 scfm under the following conditions:

Inlet pressure = 100 psig (6.7 bar)  
Pressure drop = 10 psi (0.69 bar)  
Air temperature = 68°F (20°C)  
Relative humidity = 36%

**Note:** Because widely differing test standards are used to measure  $C_v$  values, the figures given in this catalog should not be used to compare ROSS valves with those of other makers. The  $C_v$  ratings given here are intended only for use with performance charts published by ROSS. The  $C_v$  ratings are averages for the various flow paths through the valve and are for steady flow conditions.

## Approvals and Certifications

ROSS products are designed to meet a number of industrial standards, including the Canadian Standards Association (C.S.A.) guidelines. For more information on specific product approvals, contact your local distributor or ROSS.

## Solenoids

All ROSS standard solenoids are rated for continuous duty (unless noted otherwise) and will operate the valve within the air pressure range specified in this catalog.

**Explosion-Proof Solenoid Pilot available, for more information consult ROSS.**

## Voltage & Hertz

When ordering a solenoid valve, also specify the desired solenoid voltage and hertz.

Voltage Types by Model Suffix Letter

Voltage	Suffix Letter
120 volts AC	Z
220 volts AC	Y
12 volts DC	H
24 volts DC	W
48 volts DC	M
90 volts DC	K
110 volts DC	P
125 volts DC	C

**Recommended Solenoid Voltages:** 100-110 volts AC, 50 Hz; 100-120 volts AC, 60 Hz; 24 volts DC; 110 volts DC.

In addition, the following voltages are available:

200, 220 volts AC, 50 Hz  
200, 240, 480 volts AC, 60 Hz  
24, 48, 220 volts AC, 50 Hz  
240 volts AC, 60 Hz  
200, 220 volts AC, 50 Hz  
200, 240 volts AC, 60 Hz.

For example: Model 2773B5001, 120 volts AC, 60 Hz.  
Model W6076B2401, 220 volts AC, 50 Hz.

**Please note that not all configurations are available for all models.**

*For additional information or help with voltage configuration, please contact your local distributor or ROSS.*

## Port Identification

Valve symbols in this catalog conform to the ISO 1219-1:1991 standard of the International Organization for Standardization (ISO) and the SAE J2051 standard of the Society of Automotive Engineers (SAE) respectively.

## Information or Technical Assistance

For additional information or application assistance concerning ROSS products, consult ROSS or your local ROSS distributor (see contact information on the back cover).

## Order Placement

**For order placement, consult ROSS or your local ROSS distributor.**

For a current list of countries and local distributors, visit ROSS' website at [www.rosscontrols.com](http://www.rosscontrols.com).



# CAUTIONS, WARNINGS and STANDARD WARRANTY

## PRE-INSTALLATION or SERVICE

1. Before servicing a valve or other pneumatic component, be sure that all sources of energy are turned off, the entire pneumatic system is shut off and exhausted, and all power sources are locked out (ref: OSHA 1910.147, EN 1037).
2. All ROSS products, including service kits and parts, should be installed and/or serviced only by persons having training and experience with pneumatic equipment. Because any installation can be tampered with or need servicing after installation, persons responsible for the safety of others or the care of equipment must check every installation on a regular basis and perform all necessary maintenance.
3. All applicable instructions should be read and complied with before using any fluid power system in order to prevent harm to persons or equipment. In addition, overhauled or serviced valves must be functionally tested prior to installation and use. If you have any questions, call your nearest ROSS location listed on the cover of this document.
4. Each ROSS product should be used within its specification limits. In addition, use only ROSS parts to repair ROSS products.

**WARNING: Failure to follow these directions can adversely affect the performance of the product or result in the potential for human injury or damage to property.**

## FILTRATION and LUBRICATION

5. Dirt, scale, moisture, etc. are present in virtually every air system. Although some valves are more tolerant of these contaminants than others, best performance will be realized if a filter is installed to clean the air supply, thus preventing contaminants from interfering with the proper performance of the equipment. ROSS recommends a filter with a 5-micron rating for normal applications.
6. All standard ROSS filters and lubricators with polycarbonate plastic bowls are designed for compressed air applications only. Do *not* fail to use the metal bowl guard, where provided, to minimize danger from high pressure fragmentation in the event of bowl failure. Do not expose these products to certain fluids, such as alcohol or liquefied petroleum gas, as they can cause bowls to rupture, creating a combustible condition, hazardous leakage, and the potential for human injury or damage to property. Immediately replace a crazed, cracked, or deteriorated bowl. When bowl gets dirty, replace it or wipe it with a clean dry cloth.

7. Only use lubricants which are compatible with materials used in the valves and other components in the system. Normally, compatible lubricants are petroleum based oils with oxidation inhibitors, an aniline point between 180°F (82°C) and 220°F (104°C), and an ISO 32, or lighter, viscosity. Avoid oils with phosphate type additives which can harm polyurethane components, potentially leading to valve failure which risks human injury, and/or damage to property.

## AVOID INTAKE/EXHAUST RESTRICTION

8. Do not restrict the air flow in the supply line. To do so could reduce the pressure of the supply air below the minimum requirements for the valve and thereby cause erratic action.
9. Do not restrict a valve's exhaust port as this can adversely affect its operation. Exhaust silencers must be resistant to clogging and must have flow capacities at least as great as the exhaust capacities of the valves. Contamination of the silencer can result in reduced flow and increased back pressure.

**WARNING: ROSS expressly disclaims all warranties and responsibility for any unsatisfactory performance or injuries caused by the use of the wrong type, wrong size, or an inadequately maintained silencer installed with a ROSS product.**

## POWER PRESSES

10. Mechanical power presses and other potentially hazardous machinery using a pneumatically controlled clutch and brake mechanism must use a press control double valve with a monitoring device. A double valve without a self-contained monitoring device should be used only in conjunction with a control system which assures monitoring of the valve. All double valve installations involving hazardous applications should incorporate a monitoring system which inhibits further operation of the valve and machine in the event of a failure within the valve mechanism.

## ENERGY ISOLATION/EMERGENCY STOP

11. Per specifications and regulations, ROSS L-O-X® and L-O-X® with EEZ-ON® operation products are defined as energy isolation devices, NOT AS EMERGENCY STOP DEVICES.

## STANDARD WARRANTY

limited to repair or replacement of the product or refund of the purchase price paid solely at the discretion of ROSS and provided such product is returned to ROSS freight prepaid and upon examination by ROSS is found to be defective. This warranty becomes void in the event that product has been subject to misuse, misapplication, improper maintenance, modification or tampering.

THE WARRANTY EXPRESSED ABOVE IS IN LIEU OF AND EXCLUSIVE OF ALL OTHER WARRANTIES AND ROSS EXPRESSLY DISCLAIMS ALL OTHER WARRANTIES EITHER EXPRESSED OR IMPLIED WITH RESPECT TO MERCHANTABILITY OR FITNESS FOR A PARTICULAR PURPOSE. ROSS MAKES NO WARRANTY WITH RESPECT TO ITS PRODUCTS MEETING THE PROVISIONS OF ANY GOVERNMENTAL OCCUPATIONAL SAFETY AND/OR HEALTH LAWS OR REGULATIONS. IN NO EVENT IS ROSS LIABLE TO PURCHASER, USER, THEIR EMPLOYEES OR OTHERS FOR INCIDENTAL OR CONSEQUENTIAL DAMAGES WHICH MAY RESULT FROM A BREACH OF THE WARRANTY DESCRIBED ABOVE OR THE USE OR MISUSE OF THE PRODUCTS. NO STATEMENT OF ANY REPRESENTATIVE OR EMPLOYEE OF ROSS MAY EXTEND THE LIABILITY OF ROSS AS SET FORTH HEREIN.

All products sold by ROSS CONTROLS are warranted for a one-year period [with the exception of all Filters, Regulators and Lubricators ("FRLs") which are warranted for a period of seven years] from the date of purchase to be free of defects in material and workmanship. ROSS' obligation under this warranty is





**ROSS CONTROLS**  
U.S.A.

Tel: +1-248-764-1800  
Customer Svs. 1-800-GET-ROSS  
(438-7677)  
Technical Svs. 1-888-TEK-ROSS  
(835-7677)

[sales@rosscontrols.com](mailto:sales@rosscontrols.com)  
[www.rosscontrols.com](http://www.rosscontrols.com)

**ROSS EUROPA GmbH**  
Germany

Tel: +49-6103-7597-0  
[sales@rosseuropa.com](mailto:sales@rosseuropa.com)  
[www.rosseuropa.com](http://www.rosseuropa.com)

**ROSS ASIA K.K.**  
Japan

Tel: +81-42-778-7251  
[www.rossasia.co.jp](http://www.rossasia.co.jp)

**ROSS UK Ltd.**  
United Kingdom

Tel: +44-1543-671495  
[sales.uk@rosscontrols.com](mailto:sales.uk@rosscontrols.com)  
[www.rossuk.co.uk](http://www.rossuk.co.uk)

**ROSS CONTROLS INDIA Pvt. Ltd.**  
India

Tel: +91-44-2624-9040  
[ross.chennai@rosscontrols.com](mailto:ross.chennai@rosscontrols.com)

**ROSS SOUTH AMERICA Ltda.**  
Brazil

Tel: +55-11-4335-2200  
[vendas@rosscontrols.com](mailto:vendas@rosscontrols.com)

**ROSS FRANCE SAS**  
France

Tel: +33-1-49-45-65-65  
[www.rossfrance.com](http://www.rossfrance.com)

**ROSS CONTROLS (CHINA) Ltd.**  
China

Tel: +86-21-6915-7961  
[sales@rosscontrols.com.cn](mailto:sales@rosscontrols.com.cn)  
[www.rosscontrolschina.com](http://www.rosscontrolschina.com)

**ROSS CANADA**  
Canada

Tel: +1-416-251-7677  
[sales@rosscanada.com](mailto:sales@rosscanada.com)  
[www.rosscanada.com](http://www.rosscanada.com)

6077170 CANADA INC.  
AN INDEPENDENT REPRESENTATIVE



## ***Full-Service Global Locations***

***There are ROSS Distributors Throughout the World***

---

*To meet your requirements across the globe, ROSS distributors are located throughout the world. Through ROSS or its distributors, guidance is available for the selection of ROSS products, both for those using pneumatic components for the first time and those designing complex pneumatic systems.*

*Other literature is available for engineering, maintenance, and service requirements. If you need products or specifications not shown here, please contact ROSS or your ROSS distributor. They will be happy to assist you in selecting the best product for your application.*

---

***For a current list of countries and local distributors, visit ROSS' website at [www.rosscontrols.com](http://www.rosscontrols.com).***